

Aquafil Elegri

Drinking Fountain and Bottle Refill Station

SKU: AQ-EL1000BF

Bring functionality and style together with the Aquafil Elegri. The fountain features a thoughtfully designed basin with a sculpted arch. This allows any excess water to flow smoothly into an underground drainage cage. This discreet feature keeps the area clean and tidy.

Wheelchair accessibility, easy-to-use buttons or foot pedal activation make this an inclusive and hygienic fountain and bottle refill option for architectural settings.

Combine durability, performance, and an attractive design with the Aquafil Elegri. An excellent choice for premium outdoor settings and community areas.

Key Inclusions

- Water Bottle Refill Point
(AS1428.2 1992 Compliant)
- Drinking Fountain
- Stainless Steel Construction
- Stainless Steel Buttons
- Foot Pedal Activation



Technical Details

Housing Frame	Stainless steel
Water Supply Connections	3/4" supply line with 1/2" male BSP connection
Drainage Cage Connection	90mm PVC
Shipping Dimensions	220 x 120 x 50cm
Shipping Weight	40kg

Specification Text

Aqua*fil* Outdoor Drinking Water Station - 1178H x 192W x 704D. Complete with drinking fountain, AS1428.2 1992 compliant bottle filler and inground drainage cage. Structured with stainless steel. Push button or foot pedal activation options. Optional installation and maintenance package. Product Code AQ-EL1000BF.

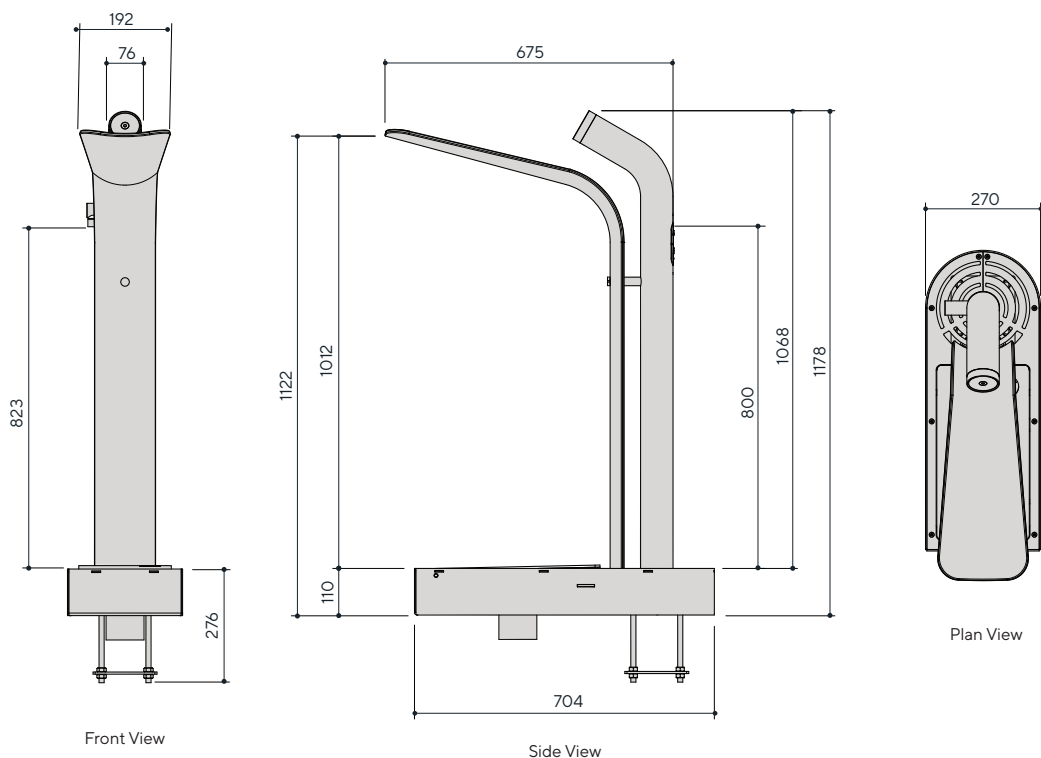

Visit civiq.com.au to access the most recent data, CAD files and installation instructions.