

Aquafil FlexiFountain 1500BFF

Drinking Fountain and Bottle Refill Station

SKU: AQ-FF1500BFF

A standout drinking water station, with large-scale custom graphic panels - suitable for people of all ages and abilities. Dual-height drinking fountains and water bottle refill points mean the station provides access to fresh and clean drinking water to everyone in the community.

Ideal for parks, playgrounds, beachside and urban settings, as well as busy outdoor school campuses and sports grounds.

Key Inclusions

- Two Water Bottle Refill Points (AS1428.2 1992 Compliant)
- Two Drinking Fountains
- Stainless Steel Construction
- Stainless Steel Buttons
- Drainage Cage
- Custom Art Panels with UV and Anti-Graffiti Protection

Customisation Options

- Dog Bowl
- Filter
- Indoor or Outdoor Remote Chiller
- Water Meter
- Thermal Plumbing Insulation
- Frost Protection Device
- Service Tap

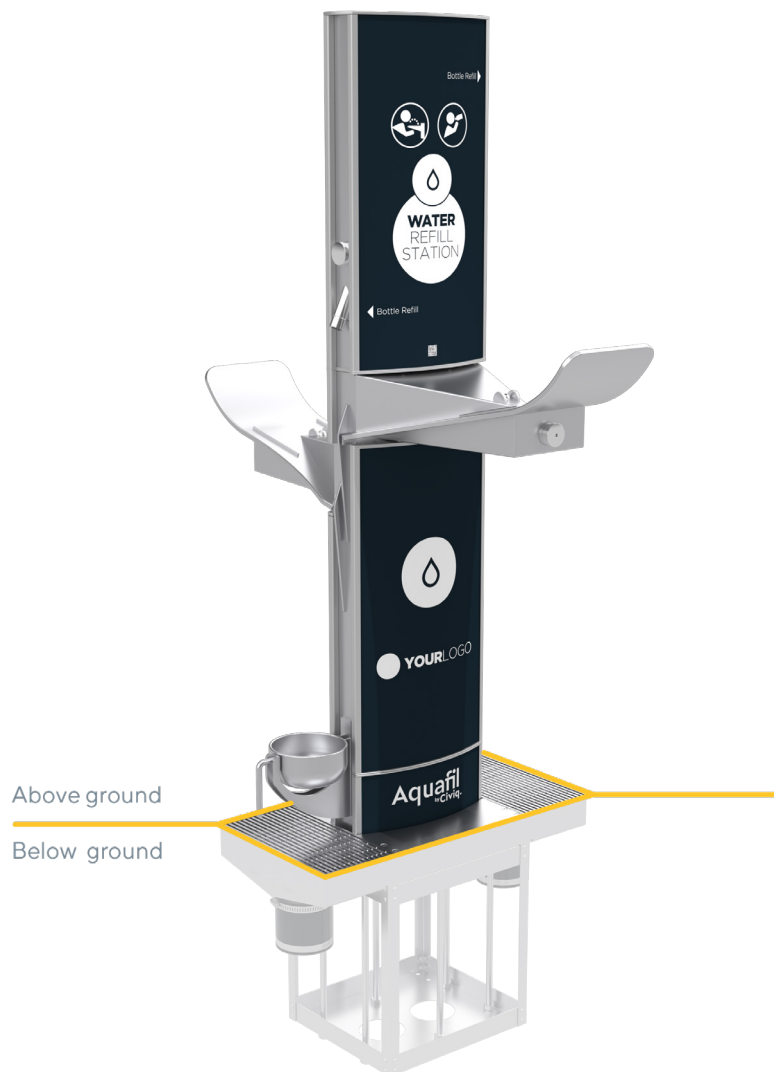

Technical Details

Housing Frame	Stainless steel
Housing Unit	Anodised aluminium
Graphic Panels	Stainless steel
Filter Unit Position	Sub-micron or 5 micron
Filter Unit Working Pressure	10-125 psi (0.7-8.5 bar), non-shock
Water Supply Connections	1/2" supply line with 1/2" male BSP connection
Drainage	2 x 90mm PVC
Shipping Dimensions	160 x 120 x 50cm
Shipping Weight	95kg

Specification Text

Aquafil Indoor or Outdoor Drinking Water Station - 1455H x 1045W x 640D. Complete with drainage cage and AS1428.2 1992 compliant bottle fillers and two drinking fountains at different heights. Full stainless-steel construction with UV and anti-graffiti protected interchangeable custom graphic panels. Optional dog bowl, filter, chiller, meter, thermal plumbing insulation, frost protection device, and maintenance package.
Product Code AQ-FF1500BFF.

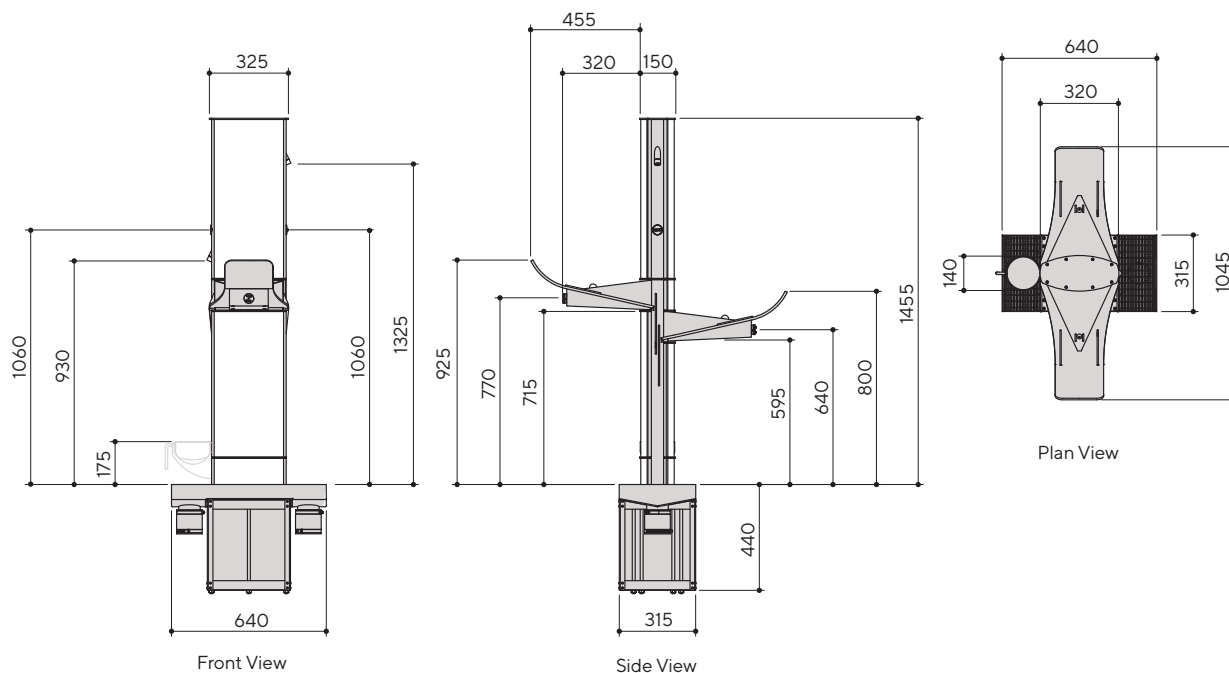

Visit civiq.com.au to access the most recent data, CAD files and installation instructions.