

# Aquafil FlexiShower

## Installation Details

AQ-FS-2100SS/DS/DF

### 1. EXCAVATE

Excavate a footing 500mm deep x 850mm long x 520mm wide.

### 2. LEVEL

Ensure cage is level.

If ground is not level, one edge must be flush with highest footing edge.

### 3. WATER

Install water supply through the water access hole and extend 100mm above ground level.

### 4. DRAINAGE

Connect 90mm Plumbqwik to stormwater drain system or soaker pit.

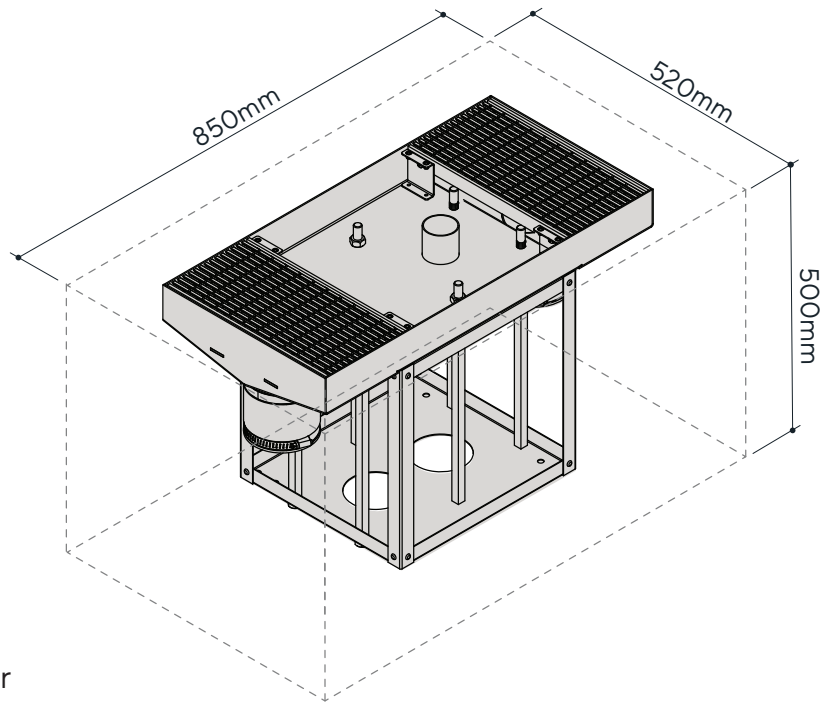

*\*Civiq recommends Everhard Series 450 Stormwater Pit. Refer to manufacturers instructions regarding site preparation and correct installation.*

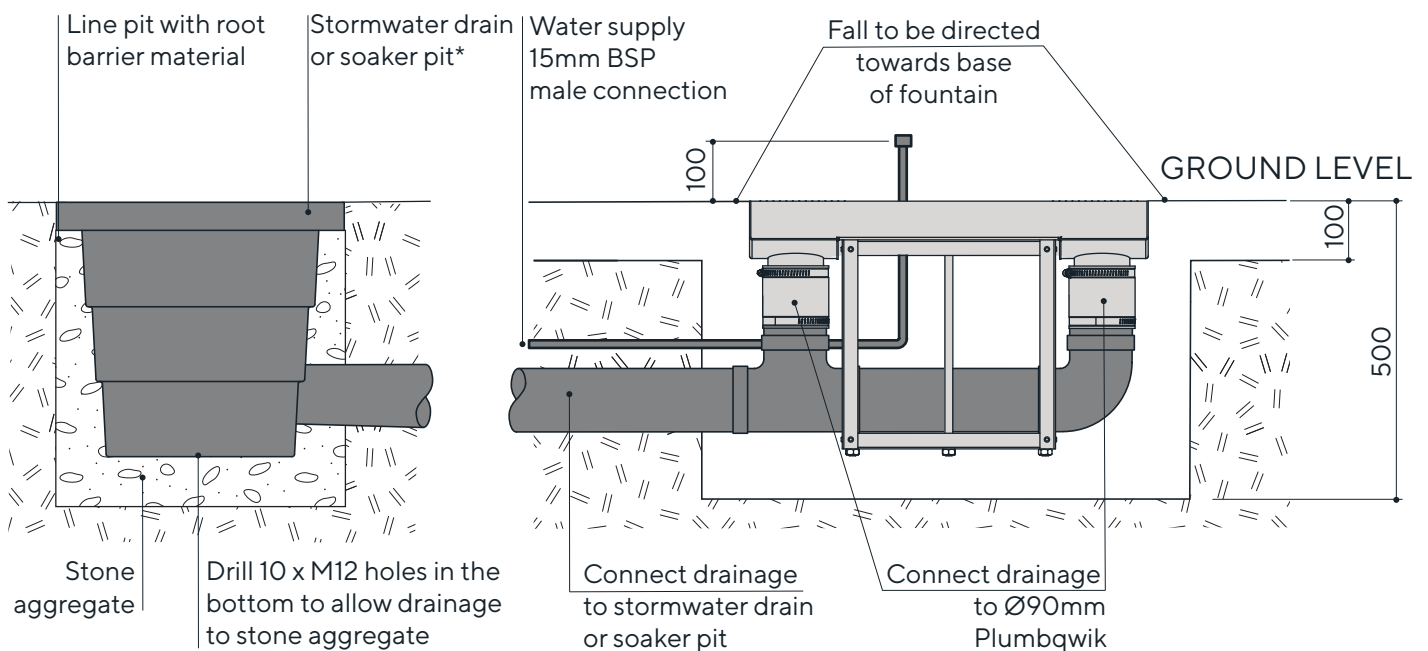

# Aquafil FlexiFountain

## Installation Details

AQ-FS-2100SS/DS/DF

### 5. CONCRETE

Pour 20mpa concrete into drainage cage. Slab should be a 100mm thick under the product for wheelchair users.

### 6. CURE

Allow concrete mix cure for 2 days before installing the product.

### 7. REMOVE

Remove cover plates and grates by unscrewing 8 x M5 screws.

### 8. INSTALL

Bolt the product to the drainage cage bolts using 6 x M12 nuts.

### 9. CONNECT

Remove service panel at lower front of product to access the internal plumbing. Connect the product to the water supply via a 15mm BSP flexible hose.

### 10. REPLACE

Re-install grates and cover plates. Ensure the screws are put back into place.

