

# Aquafil Solo 700B

## Bottle Refill Station

SKU: AQ-SO700B

Compact, colourful and cost-effective. The Aquafil Solo range of drinking water stations offers a compact, sustainable and multi-purpose solution for outdoor areas. Large, interchangeable panels combine easy access to drinking water with custom branding or graphics.

Ideal for outdoor areas, including schools, and educational institutions.

### Key Inclusions

- Two Water Bottle Refill Points
- Stainless Steel Construction
- Stainless Steel Buttons
- Custom Art Panels with UV and Anti-Graffiti Protection

### Customisation Options

- Filter
- Chiller (With Optional Water Meter)



## Technical Details

Housing Frame	Stainless steel
Housing Unit	Anodised aluminium
Graphic Panels	Stainless steel
Filter	Sub-micron or 5 micron
Filter Working Pressure	10-125 psi (0.7-8.5 bar), non-shock
Water Supply Connections	3/4" supply line with 1/2" male BSP connection
Drainage	50mm PVC
Shipping Dimensions	90 x 40 x 50cm
Shipping Weight	33kg

## Specification Text

Aquafil Outdoor Drinking Water Station - 724H x 359W x 296D.

Complete with two wheelchair-accessible bottle fillers on both sides. Stainless-steel and aluminium construction with UV and anti-graffiti protected interchangeable custom graphic panels. Optional filter, chiller with optional meter, installation, and maintenance package. Product Code AQ-SO700B.

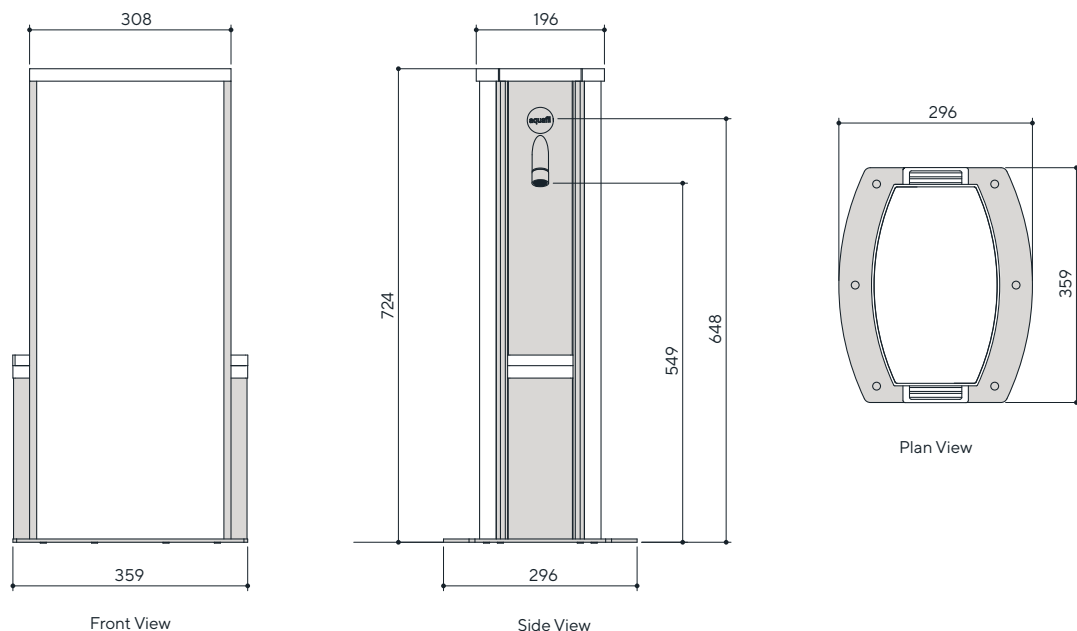

Visit [civiq.com.au](http://civiq.com.au) to access the most recent data, CAD files and installation instructions.